

**WEIGHT RATINGS**

GVM: 17,995kg  
 GCM: N/A

**ENGINE PERFORMANCE**

Power: 231kW (310 hp) @ 2300rpm  
 Torque: 1200Nm @ 1200 to 1500rpm

**TRANSMISSION**

ZF 9-sp Automated  
 Manual Transmission

**SAFETY FEATURES**

Anti-Lock Braking System	(ABS)	●
Electronic Stability Program	(ESP)	●
Lane Departure Warning System	(LDWS)	●
Auto Brake Hold	(ABH)	●
Electronic Brake System	(EBS)	●
Autonomous Emergency Braking	(AEB)	●
Forward Collision Warning	(FCW)	●
Daytime Running Lights	(DRL)	●

**SAFETY FEATURES**

ECE-R29 Cab Strength Compliant	●
Full Air Brake System	●
Reverse Camera, Sensors & Buzzer	●
Electronic Air Park Brake	●
Drivers Seatbelt Warning	●
Front and Rear Fog Lamps	●
Cruise Control & Bluetooth (Handsfree)	●
Auto-sensing & Adjustable Head Lights	●

● = Standard Feature | ○ = Optional Feature

ENGINE	
Model	CUMMINS ISD6.7 EU6
Type	Diesel 6-cylinder in-line with turbo-intercooler
Emission Control	SCR+DOC+DPF (Euro 6 compliant)
Displacement	6,700cc
Bore x Stroke	107 x 124mm
Compression Ratio	18.5 : 1

PERFORMANCE	
Max. Power	231kW (310hp) @ 2300rpm
Max. Torque	1200Nm @ 1200 - 1500rpm
Fuel Injection	Electronic High-Pressure Common-Rail

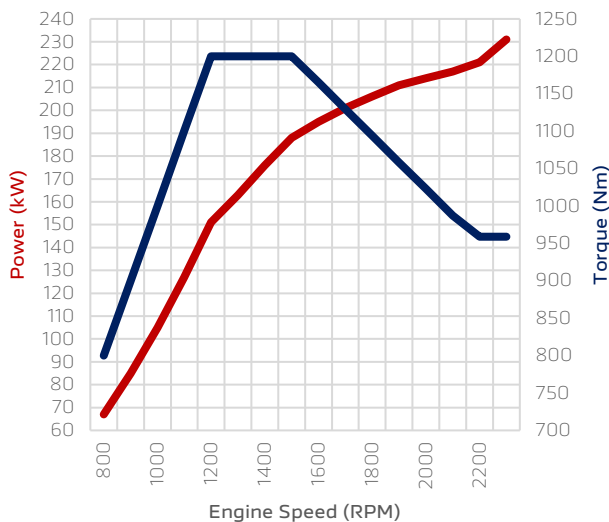
**Foton Cummins ISD6.7 EVIE320**

TRANSMISSION	
Model	ZF 9AS157TO (AMT)
Gear Ratios	(1): 10.51      (2): 6.58
	(3): 4.68      (4): 3.48
	(5): 2.62      (6): 1.89
	(7): 1.35      (8): 1.00
	(9): 0.75      (R): 8.97
	PTO Provision
Driving Modes	Economy/Power & Low Speed

CLUTCH	
Type	Dry Single Plate, Diaphragm Spring Clutch
Actuation	Electrical Air
Diameter	430mm

STEERING	
Type	Dual Circuit Recirculating Ball
Power Assist Type	Hydraulic Boost
Turning Circle	19.45m

SUSPENSION	
Front	Type: Multi Leaf Spring (3) + Stabiliser Bar
	Shocks: Equipped (Double Acting)
Rear	Type: Air Bag (2) with ECAS
	Shocks: Equipped (Double Acting)

BRAKES	
Front	Type: Ventilated Disc
	Diameter: 400mm
Rear	Type: Ventilated Disc
	Diameter: 430mm
System	Dual Circuit Air Brake
Air Tanks	Aluminium Alloy
Park Brake	Electronic Air Activated (Rear)
Features	ABS, ESP, EBS, AEB, EPB, ABH
Auxiliary	Exhaust Brake

AXLES	
Front	Type: Forged & Stamped I-Beam
	Max: 7,200kg <sup>1</sup>
Rear	Type: Banjo (Stamped & Welded Housing)
	Max: 13,000kg <sup>1</sup>
	Ratio: 4.875 : 1

ELECTRICAL	
System Voltage	24V
Alternator Capacity	70A
Battery Capacity	2 x 135Ah Maintenance Free Batteries
Starter Motor	28V / 6kW output

● = Standard Feature | ○ = Optional Feature

**WHEELS & TYRES**

Type	Aluminium Alloy	
Front	<b>Tyres:</b>	295/80 R22.5
	<b>Load Index:</b>	152/149
	<b>Max Tyre Rating:</b>	7,110kg <sup>1</sup>
	<b>Rim Size:</b>	22.5" x 9.0"
	<b>Rim Offset:</b>	175 ± 5mm
	<b>PCD:</b>	285.75mm
Rear	<b>Tyres:</b>	295/80 R22.5
	<b>Load Index:</b>	152/149
	<b>Max Tyre Rating:</b>	13,000kg <sup>1</sup>
	<b>Rim Size:</b>	22.5" x 9.0"
	<b>Rim Offset:</b>	175 ± 5mm
Number of Studs	10	

**FUEL & ADBLUE® TANK**

<b>Fuel Tank Capacity</b>	450L with Locking Cap
<b>Fuel Tank Material</b>	Aluminium Alloy
<b>AdBlue® Capacity</b>	25L with Locking Cap

**EXTERIOR FEATURES**

Cab	4-Point Air Suspended Rest Cab
	ECE-R29 Cab Strength Compliant
	Forward Control Hydraulic Tilt Function
Lighting	Auto-sensing and adjustable integrated LED headlights
	LED Daytime Running Lights (DRL)
	Front and Rear Fog Lamps
	LED Roof Clearance Lights
	Combination Tail Lights
Mirrors	2 x Heated & Power Adjustable Side Mirrors
	1 x Roof Mounted Curb-view Mirror
Other	2-Speed Variable Intermittent Wipers

**CAB INTERIOR**

Steering Wheel	2-Way Adjustable (Telescopic & Tilt)
	Audio, Cruise Control & Bluetooth® controls
Seating / Sleeping	3 x Seating Capacity
	2 x Air Sprung Climate Control Grammer Seats
	1 x Sleeping Capacity
Infotainment	LCD Touch Screen
	2 x Speakers
	AM/FM Radio
	Reverse Camera
	Bluetooth® (Handsfree)
Storage	USB Port & SD Card Slot
	3 x Overhead Shelves
	1 x Door Pocket
Other	1 x Centre Console
	Cruise Control
	Climate-Control HVAC System
	Remote Central Locking
	Anti-Pinch Electrical Power Windows
	3 x Cup Holders
	2 x Power Outlets (24V/15A)
	2 x Courtesy Step Lights
	Dual-mode Horn (Electrical & Air)

**CHASSIS FRAME**

<b>Chassis Type</b>	Longitudinal Beam High Strength Steel
<b>Pre-Drilled</b>	Equipped
<b>Dimensions</b>	234 x 65 (Front) / 75 (Rear) x (6 + 4) mm
<b>Tensile Strength</b>	700 - 880MPa

**VEHICLE MASSES**

<b>GVM<sup>1</sup></b>	11,995kg / 17,995kg	
<b>Payload<sup>2</sup></b>	6,665kg / 12,665kg	
<b>Tare Weight<sup>2</sup></b>	5,330kg	
<b>Axle Tare Weights<sup>1</sup></b>	<b>Front:</b> 3,230kg	<b>Rear:</b> 2,100kg

● = Standard Feature | ○ = Optional Feature

DIMENSIONS		
Wheelbase	(WB):	5,500mm
Overall Length	(OAL):	9,400mm
Overall Width	(OAW):	2,460mm
Overall Height	(OAH):	2,780mm
External Cab Width	(ECW):	2,365mm
Front Overhang	(FOH):	1,320mm
Rear Overhang	(ROH):	2,580mm
Rear Chassis Height	(RCH):	1,008mm
Rear Chassis Width	(RCW):	865mm
Front Wheel Track	(FWT):	2,042mm
Rear Wheel Track	(RWT):	1,842mm
Cab to Chassis Height	(CCH):	1,816mm
Cab to Chassis End	(CCE):	7,270mm

WARRANTY COVER <sup>4</sup>		
Standard Warranty	5 Years / 300,000km (whichever occurs sooner)	●
Job Ready™ Body	1 Year	●

MODEL DETAILS	
Model Variant	AUMAN D – BJ1186 AMT CAB CHASSIS
Wheelbase	5,500mm

OPTIONS & ACCESSORIES			
Stoneguard	<input type="radio"/>	Exterior Sun Visor	<input type="radio"/>
Monsoons	<input type="radio"/>	Metallic Paint	<input type="radio"/>
Seat Covers	<input type="radio"/>	Air Deflector	<input type="radio"/>

● = Standard Feature | ○ = Optional Feature



JOB READY™	Flat Deck	Tipper	Box Body	Chiller	Curtainside	Recovery	Traffic Mgt	Scaff Pack
BJ1186 Range	–	–	✓	✓	✓	–	–	–

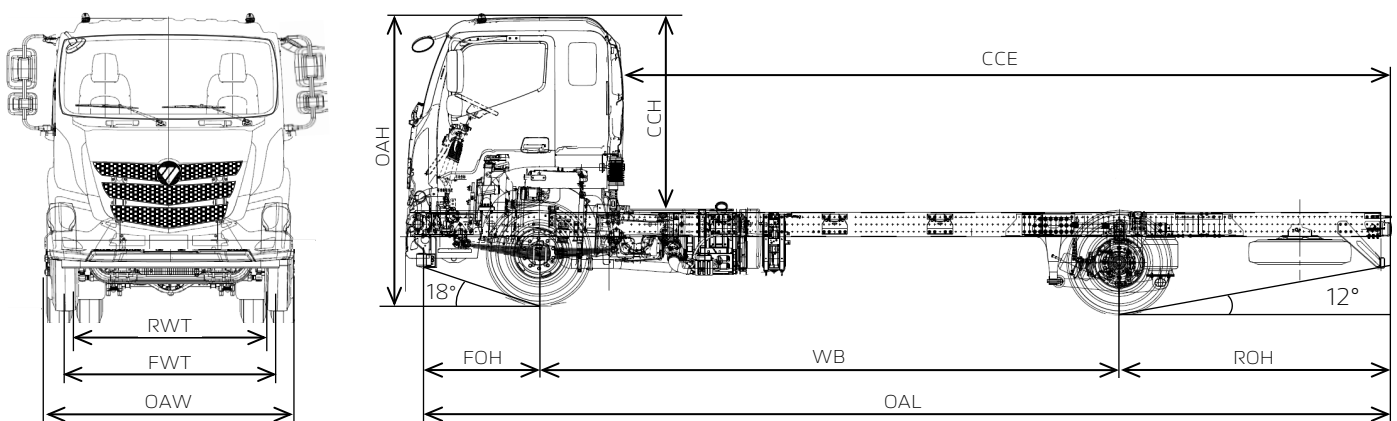

1. Vehicle load ratings & axle weight limits are subject to government regulatory requirements & weight distribution analysis. See your local Foton Truck Dealer to select the correct vehicle for your application.
2. All weights and load calculations are subject to 3% variation (+/-).
3. Maximum speed & gradability calculations are theoretical only. Actual performance may vary depending on conditions.
4. The manufacturer's 5 Year / 300,000km warranty starts from the date of first registration in NZ and applies to the base vehicle only. Foton Job Ready™ bodies have a warranty period of 12 months. To be eligible for the warranty cover, all scheduled servicing during the entire warranty period must be performed by an authorised Foton Service Agent from the date of vehicle delivery to the first customer.

Foton Trucks are distributed in New Zealand by Foton Truck NZ (Anglesea Vehicle Distributors Ltd). All effort has been made to ensure the information contained in this brochure was correct at time of printing. Foton Truck NZ reserves the right to alter any details of the specifications & equipment without notice. Foton Truck NZ, in so far as it is permitted by law to do so, shall not be liable in any way as a result of any reliance placed by any person on anything contained in this brochure. You should therefore check with your authorised Foton Truck Dealer at the time of ordering your motor vehicle to ensure that colour, specifications, equipment, design features & options are available for the vehicle you are ordering.